



PTO CABLE KIT

FOR USE WITH PUSH-PULL CONTROLS

INSTALLATION INSTRUCTIONS

PART NUMBER: 47MGM553 (10-32)
47MGM853 (1/4-28)
47MGM165-3 (5/16-24)

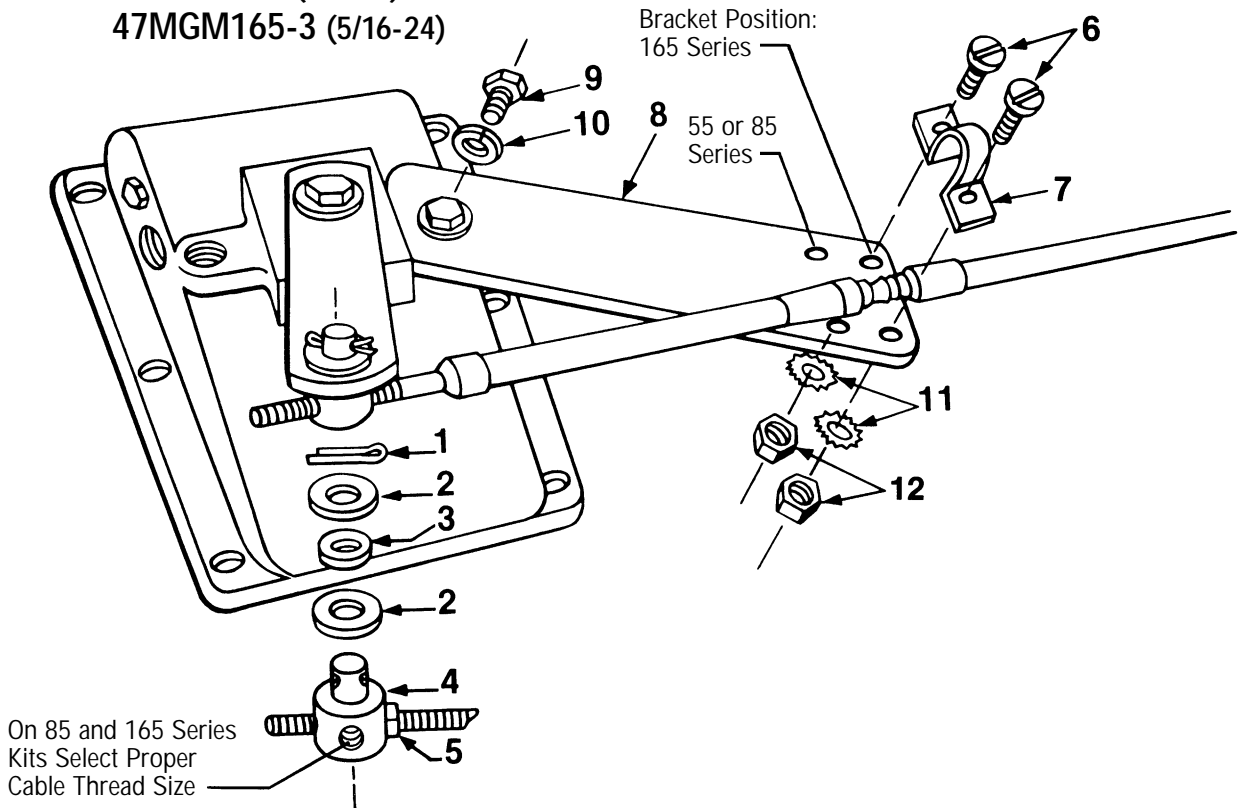

To install the bracket and control cable as shown in the illustration:

1. Place bracket (8) in best position for proper clearance and operation. It is held in place with the cap screw (9) and lock washer (10).
2. Mount a control cable of a length that will run the shortest distance with the least amount of bends. Anchor cable at several points to prevent contact with hot exhaust or moving parts. Fasten the output end of cable to the bracket by using clamp (7) and two screws (6) with nuts (12) and star washers (11) as illustrated. Select bracket position by the series of cable being used.
3. Install jam nut (5) and pivot (4) on cable end rod at center of the thread. Pivot for 55 series has only one threaded hole.
4. Reposition lever arm on spline if necessary so cable control and lever will both be at midstroke at the same time.
5. Place one washer (2) and bushing (used only in 47MGM553 kit) (3) on pivot (4) and slip through lever arm hole. Install other washer (2) and cotter key (1).
6. The control head knob should bottom against its face nut when completely depressed. When the threaded pivot (4) is in the correct location, tighten pivot jam nut (5) to maintain this adjustment.



Muncie®
Power
Products

Muncie Power Products, Inc. General Offices & Distribution Center • P.O. Box 548 • Muncie, IN 47308-0548
(765) 284-7721 • FAX (765) 284-6991 • E-mail info@munciepower.com • Web http://www.munciepower.com

Drive Products, Inc., Toronto, Exclusive Agents for Canada

